

15 Wheels/Tyres

Table of Contents

| | |
|--|-------|
| Exploded view - Front Wheel | 15.2 |
| Exploded View – Rear Wheel & Final Drive | 15.3 |
| Tyres | 15.4 |
| Tyre Pressures | 15.4 |
| Tyre Wear/Wheel Inspection | 15.4 |
| Important Tyre Information | 15.5 |
| Front Wheel | 15.6 |
| Removal | 15.6 |
| Installation | 15.7 |
| Front Wheel Bearing | 15.8 |
| Removal | 15.8 |
| Inspection | 15.8 |
| Installation | 15.9 |
| Rear Wheel | 15.10 |
| Removal | 15.10 |
| Installation | 15.10 |
| Rear Wheel Bearing | 15.11 |
| Removal | 15.11 |
| Inspection | 15.12 |
| Installation | 15.13 |

Wheels/Tyres

Exploded view - Front Wheel

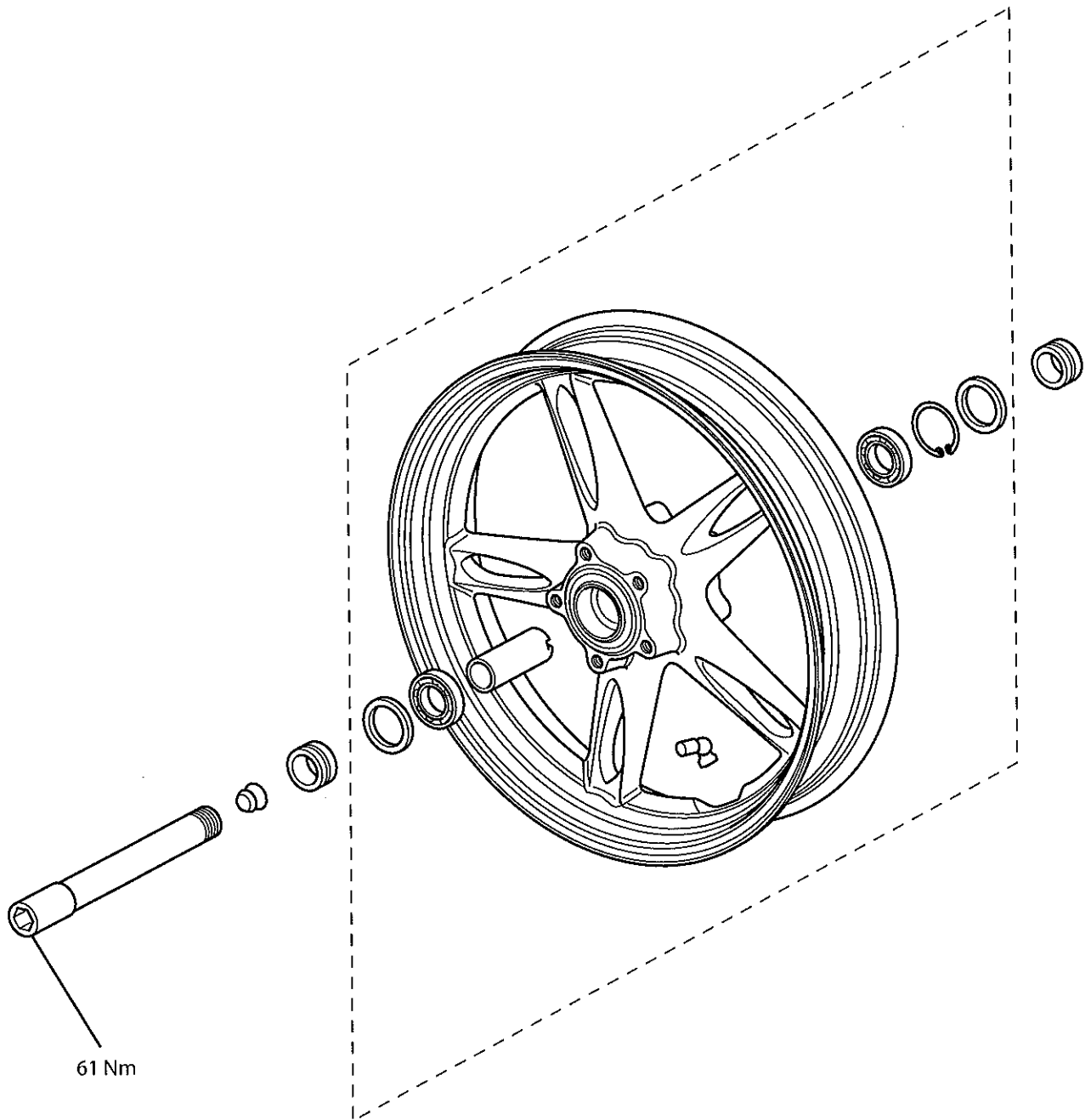

Exploded View – Rear Wheel & Final Drive

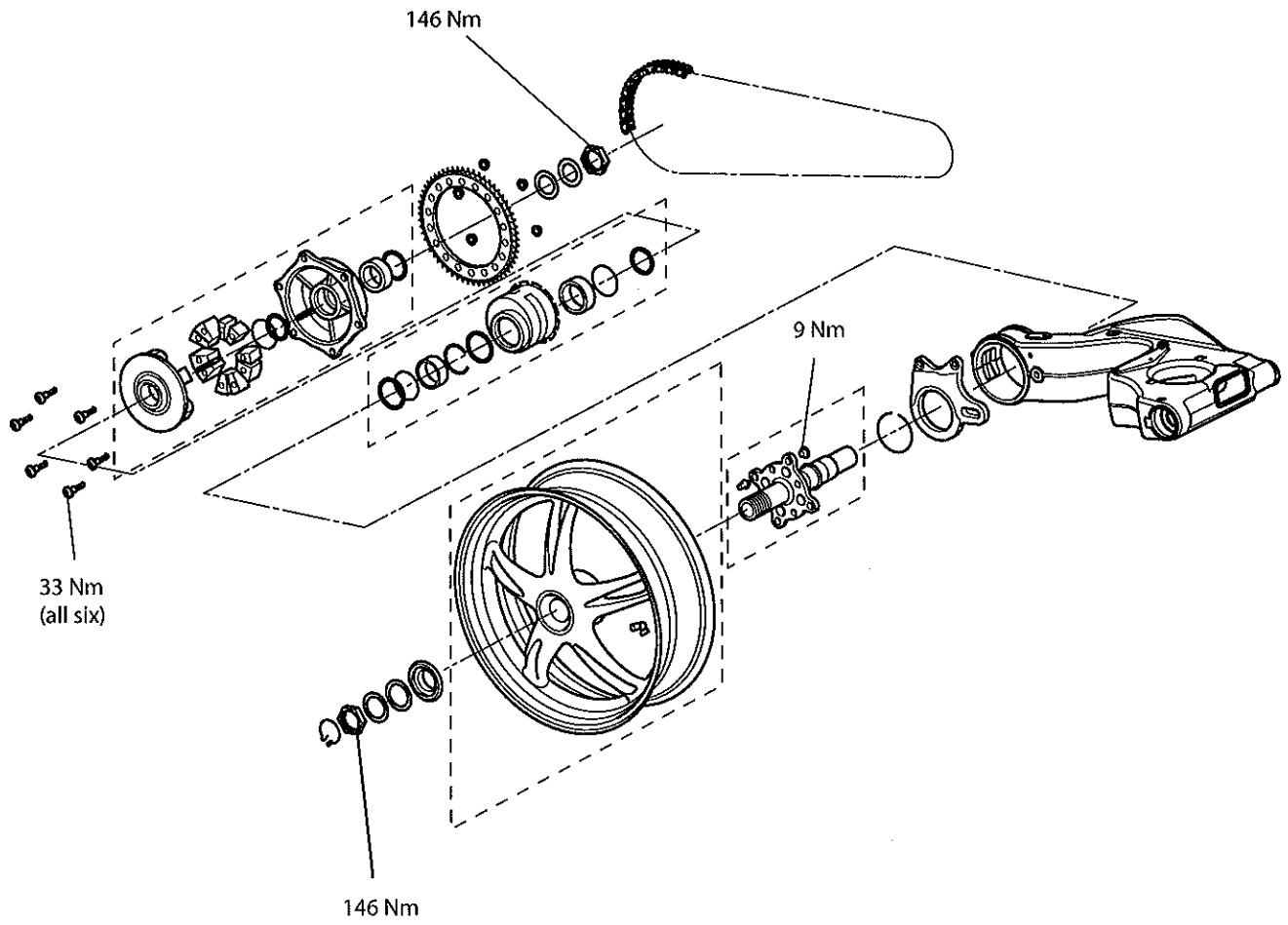

Wheels/Tyres

Tyres

This model is equipped with tubeless tyres, valves, and wheel rims. Only tyres marked 'TUBELESS' and tubeless type tyre valves mounted on rims marked 'SUITABLE FOR TUBELESS TYRES' can be used.

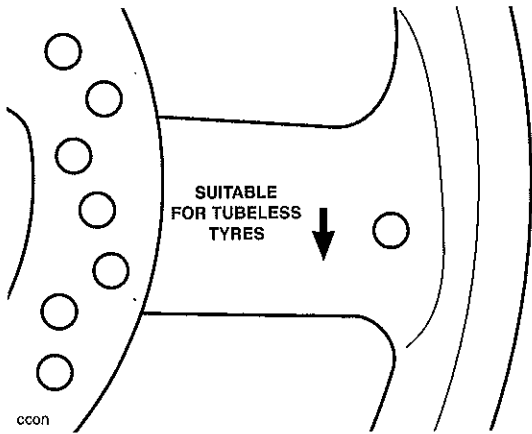

Typical Wheel Marking

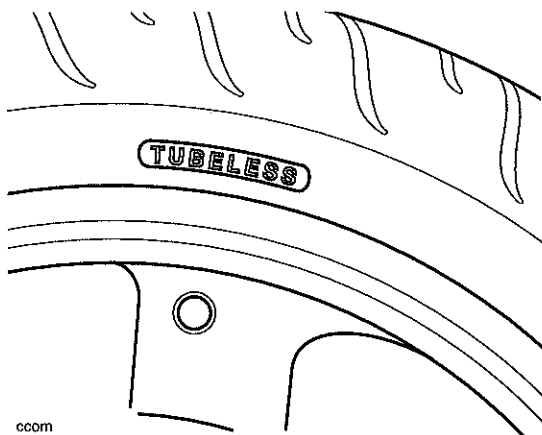

Typical Tyre Marking

Tyre Pressures

Correct inflation pressure will provide maximum stability, rider comfort and tyre life.

Tyre pressures should be checked frequently and adjusted as necessary. Correct tyre pressures are:

Front - 2.35 Bar (34 Psi)

Rear - 2.90 Bar (42 Psi)

Warning

Incorrect tyre inflation will cause abnormal tread wear and instability problems which may lead to loss of control and an accident.

Under-inflation may result in the tyre slipping on, or coming off the rim. Over-inflation will cause instability and accelerated tread wear.

Both conditions are dangerous as they may cause loss of control leading to an accident.

Tyre Wear/Wheel Inspection

As the tyre tread wears down, the tyre becomes more susceptible to puncture and failure. It is estimated that 90% of all tyre failures occur during the last 10% of tread life (90% worn). It is false economy and unsafe to use tyres until they are worn to their minimum.

All tyres are fitted with tread wear indicators. When the tyre becomes worn down as far as the top of a tread wear indicator, the tyre is worn beyond its service life and must be replaced.

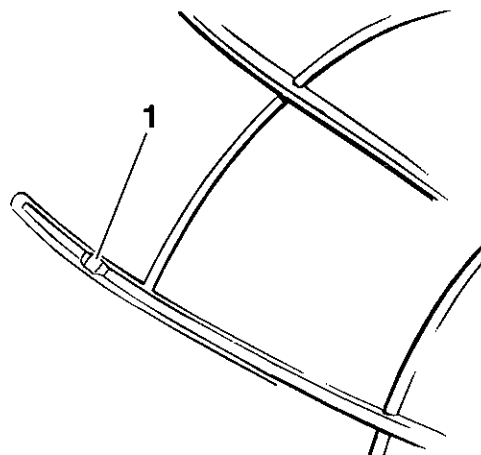

1. Tread Wear Indicator

In accordance with the scheduled maintenance chart, measure the depth of the tread with a depth gauge, and replace any tyre that has worn to, or beyond the minimum allowable tread depth.

Inspect wheels for cracks, splits and kerb damage. Always replace wheels that are suspected of having become damaged.

Warning

Tyres that have been used on a rolling road dynamometer may become damaged. In some cases, the damage may not be visible on the external surface of the tyre.

Tyres must be replaced after such use as continued use of a damaged tyre may lead to instability, loss of control and an accident.

Warning

Operation with excessively worn tyres is hazardous and will adversely affect traction, stability and handling which may lead to loss of control or an accident.

When tubeless tyres become punctured, leakage is often very slow. Always inspect tyres very closely for punctures.

Check the tyres for cuts, embedded nails or other sharp objects.

Check the rims for dents or deformation. Operation with damaged or defective wheels or tyres is dangerous and loss of control or an accident could result.

Always consult your Triumph dealer for tyre replacement, or for a safety inspection of the tyres.

Minimum Recommended Tread Depth

The following chart can be used as a guide to the minimum safe tread depth.

| Speed | Minimum Tread Depth |
|-------------------------|---|
| Under 130 km/h (80 mph) | 2 mm (0.08 in) |
| Over 130 km/h (80 mph) | Rear 3 mm (0.12 in) Front 2 mm (0.08 in) |

Warning

Triumph motorcycles must not be operated above the legal road speed limit except in authorised closed course conditions.

Important Tyre Information

All Triumph motorcycles are carefully and extensively tested in a range of riding conditions to ensure that the most effective tyre combinations are approved for use on each model. It is essential that approved tyre combinations are used when purchasing replacement tyres as the use of non approved tyres or approved tyres in non approved combinations may lead to motorcycle instability. Always refer to the owner's handbook data section for details of approved tyres and tyre combinations.

Warning

If a tyre sustains a puncture, the tyre must be replaced. Failure to replace a punctured tyre, or operation with a repaired tyre can lead to instability, loss of control or an accident.

Never use an inner tube to repair a punctured tyre. The rough surface inside the tyre can chafe the tube leading to instability, rapid deflation, loss of control and an accident.

Warning

The use of tyres other than those listed in the specification section of the owner's handbook may adversely affect handling leading to loss of control or an accident.

Use the recommended tyre options only in the combinations given in the owner's handbook.

Do not mix tyres from different manufacturers or tyres from the same manufacturer but from another option.

Warning

Always check tyre pressures before riding when the tyres are cold. Operation with incorrectly inflated tyres may affect handling leading to loss of control and an accident.

Warning

Operation with excessively worn or damaged tyres will adversely affect handling and control leading to loss of control or an accident.

Warning

Do not install tube-type tyres on tubeless rims. The bead will not seat and the tyres could slip on the rims, causing tyre deflation that may result in a loss of vehicle control and an accident.

Do not install an inner tube inside a tubeless tyre. This may cause instability and excessive heat build-up may cause the tube to burst resulting in rapid tyre deflation, loss of vehicle control and an accident.

Warning

Accurate wheel balance is necessary for safe, stable handling of the motorcycle. Do not remove or change any wheel balance weights. Incorrect wheel balance may cause instability leading to loss of control and an accident.

When wheel balancing is required, such as after tyre replacement, see your authorised Triumph Dealer.

Only use self-adhesive weights. Clip on weights will damage the wheel and tyre resulting in tyre deflation, loss of control and an accident.

Warning

When replacement tyres are required, consult your authorised Triumph Dealer who will arrange for the tyres to be fitted according to the tyre manufacturers instructions.

When tyres are replaced, allow time for the tyre to seat itself to the rim (approximately 24 hours). During this seating period, ride cautiously as an incorrectly seated tyre could cause loss of control or an accident. Initially, the new tyre will not produce the same handling characteristics as the worn tyre and the rider must allow adequate riding distance (approximately 100 miles) to become accustomed to the new handling characteristics.

After both 24 hours and 100 miles, the tyre pressures should be checked and adjusted and the tyre examined for correct seating and rectified as necessary.

Use of a motorcycle when not accustomed to its handling characteristics may lead to loss of control and an accident.

Front Wheel

Removal

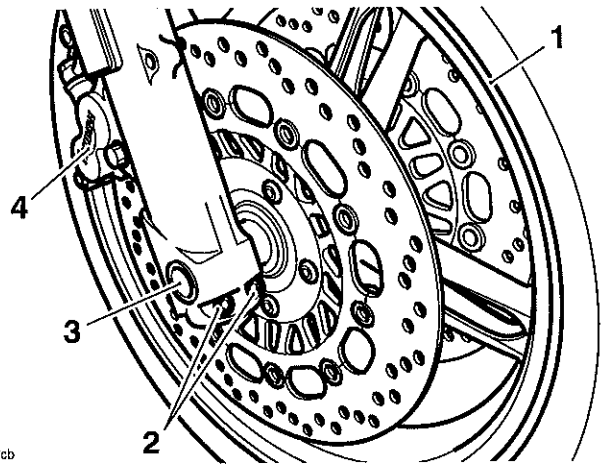

1. Front wheel
2. Fork pinch bolts
3. Wheel spindle
4. Brake caliper

1. Remove the brake caliper bolts and detach both calipers. Do not disconnect the brake hoses (see page 14-16).

Warning

Do not allow the calipers to hang on the brake hoses as this may damage the hoses and could lead to an accident.

2. Raise and support the front of the motorcycle to allow removal of the front wheel.

Warning

Ensure the motorcycle is stabilised and adequately supported, to prevent it falling and causing damage or injury.

3. Remove the four fixings from the front section of the mudguard.
4. Remove the mudguard section.
5. Slacken the two pinch bolts at the lower end of the right hand fork leg.
6. Undo the wheel spindle which is threaded into the left hand fork leg. Support the wheel and remove the wheel spindle.

- Remove the wheel, recovering the spacers from either side of the wheel. Place the wheel on wooden blocks.

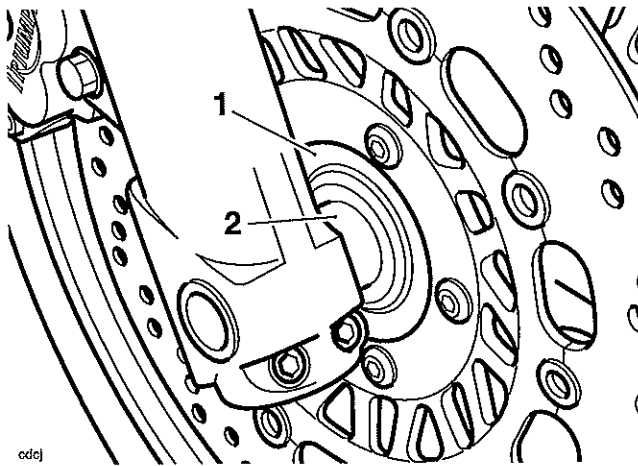

- Wheel
- Spacers

! Caution

To prevent wheel and bearing damage, ensure absolute cleanliness and ensure there is no dirt ingress to the wheel bearings while the wheel is removed.

! Warning

Do not allow the wheel to rest on either brake disc as this may damage the discs and could lead to loss of motorcycle control and an accident.

- Thoroughly clean all components and inspect for wear or damage.

Installation

- Align the wheel to the motorcycle.
- Lightly smear the sleeve surfaces with grease and locate to the seals on either side of the hub.
- Position the wheel between the forks and fit the wheel spindle.
- Tighten the wheel spindle to **61 Nm**.
- Lower the motorcycle to the ground and pump the front suspension to allow the right hand fork to 'float' to its natural position on the wheel spindle.
- Tighten the right hand fork pinch bolts to **20 Nm**.

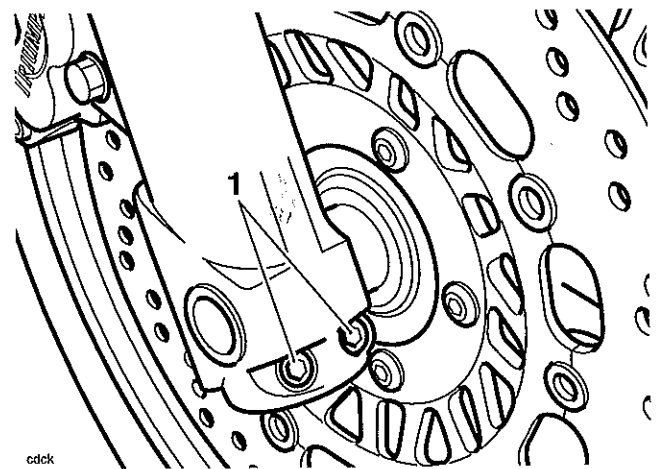

1. Fork Pinch Bolts

- Thoroughly clean and degrease the brake discs.
- Fit the brake calipers, tightening the mounting bolts to **40 Nm**.
- Check the operation of the front brake by pumping the brake lever several times.

! Warning

It is dangerous to operate the motorcycle with defective brakes and you must have your authorised Triumph Dealer take remedial action. Failure to take remedial action may reduce braking efficiency leading to loss of motorcycle control and an accident.

- Refit the front mudguard and tighten the fixings to **5 Nm**.

Front Wheel Bearing

Removal

1. Remove the front wheel (See page 15-6).
2. Models with ABS brakes: Remove the ABS pulser ring (See page 14-29).

Caution

Do not allow the wheel to rest on the brake disc, as this may damage the disc. Support the wheel on wooden blocks, equally spaced around the rim, such that the brake disc is raised above the ground.

3. Lay the wheel on its side while supporting the wheel on wooden blocks to prevent damage to the brake disc.
4. Remove and discard the seals and the bearing circlip.

Warning

Always wear eye, hand and face protection when using a drift as use of a hammer and drift can cause bearings to fragment. Pieces of fragmented bearing could cause eye and hand injuries if suitable protective apparel is not worn.

Caution

To prevent wheel damage and to aid bearing removal, always apply force evenly on both sides of the bearing to prevent it from 'tipping' and becoming stuck. Application of uneven force will lead to difficulty in removing the bearing and to a damaged wheel.

Note:

- The right hand wheel bearing must be removed first. The pin punch must be located in the cut-outs provided in the centre sleeve.

5. Using a suitable pin punch, through the centre of the wheel, drift out the right hand wheel bearing. Collect the centre sleeve. Remove the left hand wheel bearing in the same way.

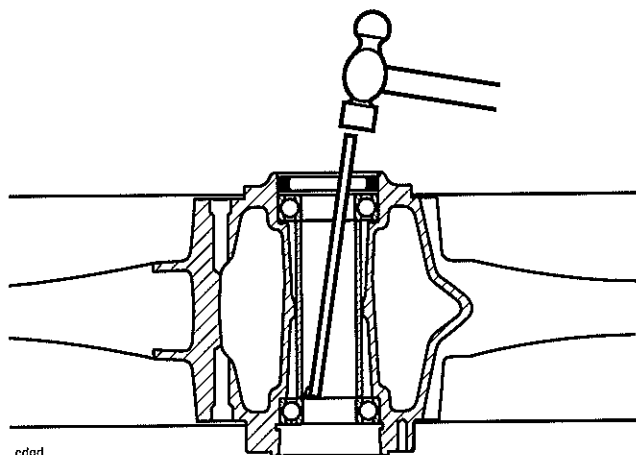

Wheel bearing removal

Inspection

Warning

Only remove raised witness marks from within the wheel. Removal of material below any raised areas will reduce the level of interference between the wheel and the bearings. Loss of interference could cause the bearing to become loose in the wheel leading to loss of motorcycle control and an accident.

1. Examine the wheel for any raised witness marks caused by the removal process. Remove any such marks with fine emery paper or a gentle file.

Wheels/Tyres

Installation

Note:

- Refer to the chart below for the correct tool and tool face when inserting bearings. Bearings are inserted by means of a draw-bolt acting on the insertion tool. A support tool is located on the opposite side of the wheel to the insertion tool and as the bolt is tightened, the bearing is drawn in to the wheel.
- Insert bearings with the marked or shielded side facing outwards and always fit a new bearing circlip and seals.

| | Bearing insertion tool | Support tool |
|---------------|--|--|
| Left bearing | 3880070-T0310 Small face to bearing | 3880075-T0310 Large face to wheel |
| Right bearing | 3880070-T0310 Small face to bearing | 3880075-T0310 Large face to bearing |

1. Fit the wheel bearings and centre sleeve using the method described above.

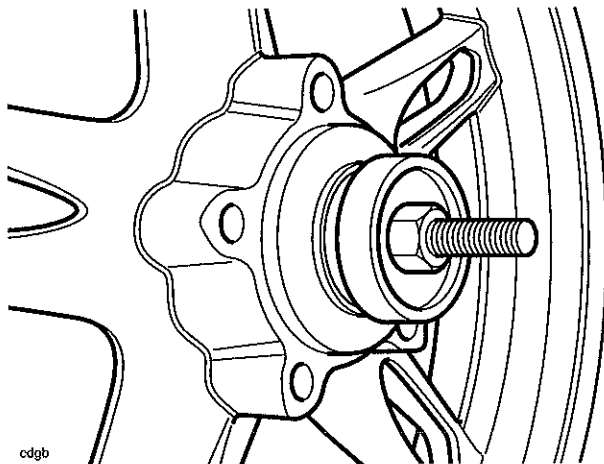

Tool 3880070 in position on wheel

2. Fit a new circlip.

⚠ Caution

The left oil seal must not contact the wheel bearing. The seal must be installed until the wheel's machined chamfer is just visible. The right hand seal must be installed until it contacts the circlip.

3. Lubricate and fit new seals to the front wheel. Lubricate the seal's knife-edge with grease to NLGI 2 specification (we recommend Mobil HP222). Install the right hand oil seal fully. Install the left hand oil seal until the wheel's machined chamfer is just visible.

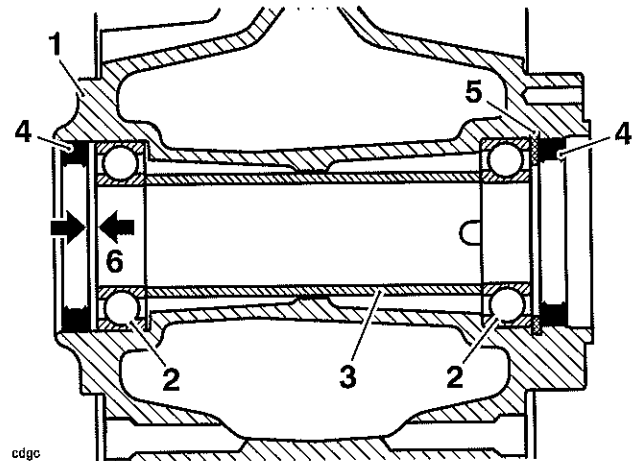

1. Front wheel
2. Wheel bearings
3. Centre Sleeve
4. Oil Seals
5. Circlip
6. Left hand oil seal position

4. Models with ABS brakes: Refit the ABS pulser ring (See page 14-30).
5. Fit the front wheel. (See page 15-7).

Wheels/Tyres

Rear Wheel

Removal



Warning

Ensure the motorcycle is stabilised and adequately supported, to prevent it falling and causing damage or injury.

1. Raise and support the rear of the motorcycle to allow removal of the rear wheel.



Warning

If the engine has recently been running, the exhaust system will be hot. Before working on or near the exhaust system, allow sufficient time for the exhaust system to cool as touching any part of a hot exhaust system could cause burn injuries.

Installation

1. Fit the wheel, aligning with the four location dowels.
2. Hold the wheel squarely in position while fitting the:
 - conical spacer
 - plain washer
 - belleville washer, dished face outwards
 - nut
3. Tighten the wheel nut to **146 Nm**, and fit the clip.

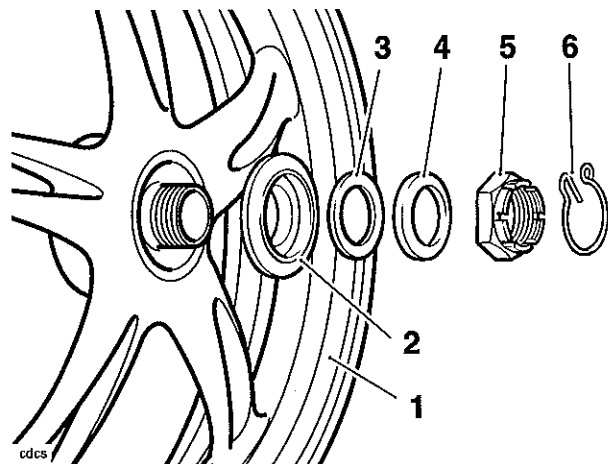

1. Rear Wheel
2. Conical spacer
3. Plain washer
4. Belleville washer
5. Nut
6. Clip

2. To release the wheel, remove:

- clip,
- nut,
- belleville washer,
- plain washer,
- conical spacer.

3. Remove the wheel.

Rear Wheel Bearing

Removal

1. Remove the rear hub (see page 12-17).
2. Transfer the hub to a work bench.
3. Note the orientation of the right hand outer hub seal then, using a soft, blunt faced tool, lever the seal from the recess in the hub.

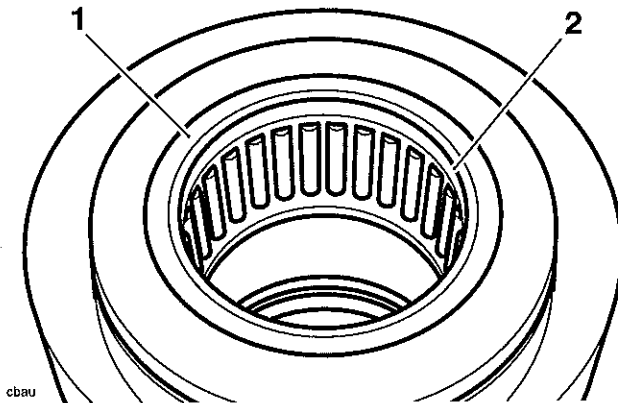

cbau

1. Seal
2. Knife-edge

4. Remove the bearing retaining ring from the right hand side of the hub.

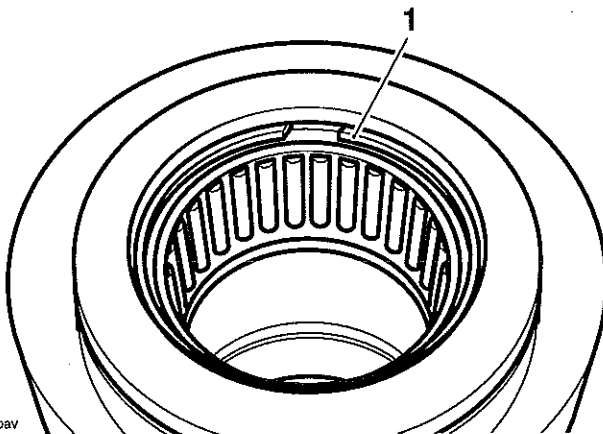

cbav

1. Bearing Retaining Ring

5. Note the orientation of the right hand inner hub seal then, while still working from the right hand side of the hub, using a similar tool as for the outer hub seal, detach the inner hub seal from within the centre of the hub.

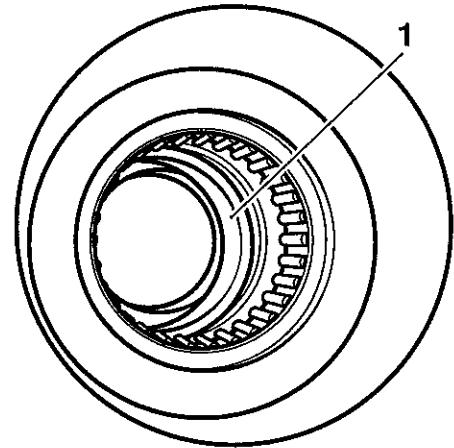

cbaw

1. Inner Hub Seal

Note:

- The right hand inner seal and circlip will remain within the hub until the bearing is removed.
- Working through the hole in the centre of the left hand bearing, detach the right hand inner circlip using circlip pliers.

Caution

Always support the hub as instructed because fully closing the vice onto the hub, supporting the hub on any other area than that specified above (particularly the eccentric adjuster slots) will cause damage and may also lead to premature wear of the new bearing once it is fitted.

6. Fit soft jaw-clamps to a vice and position the hub with the right hand side facing downwards. Do not clamp the hub in the vice. Close the vice only sufficiently to fully support the broadest possible area of the hub.

Warning

Always wear eye and hand protection when using a drift as use of a hammer and drift can cause bearings to fragment. Pieces of fragmented bearing could cause eye and hand injuries if suitable protective apparel is not worn.

⚠ Caution

To prevent hub damage and to aid bearing removal, always apply force evenly on both sides of the bearing to prevent it from 'tipping' and becoming stuck. Application of uneven force will lead to difficulty in removing the bearing and to a damaged hub.

7. Working through the hole in the centre of the left hand bearing, use a pin punch to drift out the right hand bearing.

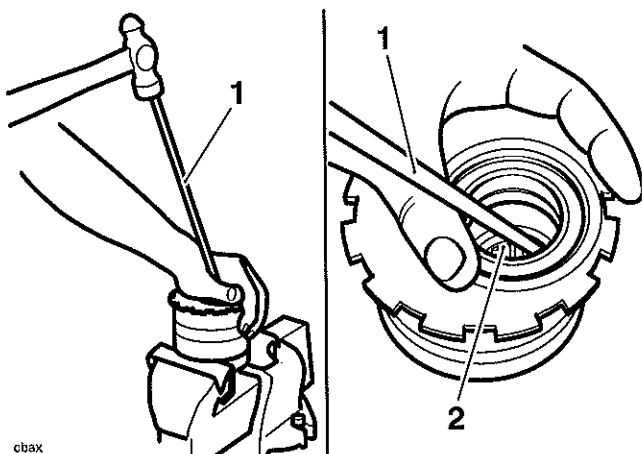

1. Punch
2. Bearing

8. Remove the inner circlip from the hub.
9. Remove the inner hub seal.
10. Remove the bearing retaining ring from the left hand side of the hub.

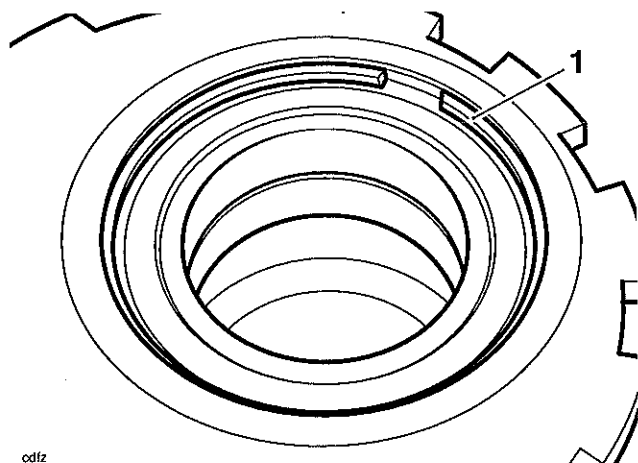

1. Bearing Retaining Ring

⚠ Warning

Always wear eye and hand protection when using a drift as use of a hammer and drift can cause bearings to fragment. Pieces of fragmented bearing could cause eye and hand injuries if suitable protective apparel is not worn.

⚠ Caution

To prevent hub damage and to aid bearing removal, always apply force evenly on both sides of the bearing to prevent it from 'tipping' and becoming stuck. Application of uneven force will lead to difficulty in removing the bearing and to a damaged hub.

11. Working through the hole in the centre of the hub, use a pin punch to drift out the left hand bearing.

Inspection

⚠ Warning

Only remove raised witness marks from within the hub. Removal of material below any raised areas will reduce the level of interference between the hub and the new bearing. Loss of interference could cause the bearing to become loose in the hub leading to loss of motorcycle control and an accident.

1. Examine the hub for any raised witness marks caused by the removal process. Remove any such marks with fine emery paper or a gentle file, taking care to ensure that filings do not contaminate the bearings.

Installation

1. Lubricate and place a new inner hub seal within the hub. Lubricate the seal's knife-edge with grease to NLGI 2 specification (we recommend Mobil grease HP222).
2. Fit a new inner circlip. Ensure the circlip is retained in the groove through its entire circumference.

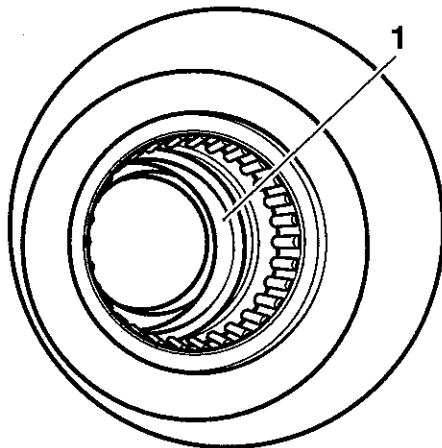

cbaw

1. Inner Circlip

3. Position the inner hub seal to the hub and push it evenly and fully into place against the inner circlip.
4. Open the vice to a distance that will accept the hub, new right hand bearing and service tool 3880065-T0301 all aligned together inside the soft vice jaws. Align the large end of tool 3880065-T0301 to the new bearing.

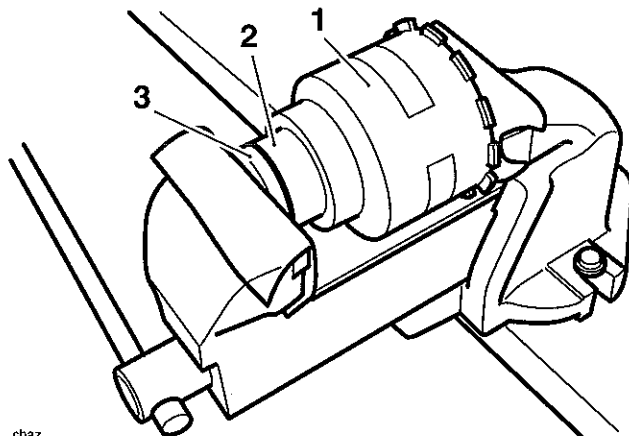

cbaz

1. Hub
2. Right hand bearing
3. Service Tool 3880065-T0301

5. Progressively close the vice until the outer cage of the new bearing is pushed fully up to the inner circlip inside the hub. Open the vice and collect the hub and tool then place the tool aside.

! Caution

Ensure the hub, new bearing and tool remain in alignment throughout the assembly process. Misalignment of any of these items could cause damage to the bearing and/or the hub.

6. Should misalignment occur at any point, remove the components, check and rectify any damage and then repeat the bearing installation process.
7. Retain the new bearing by fitting a new retaining ring to the groove inside the hub. Ensure the ring is retained in the groove through its entire circumference.

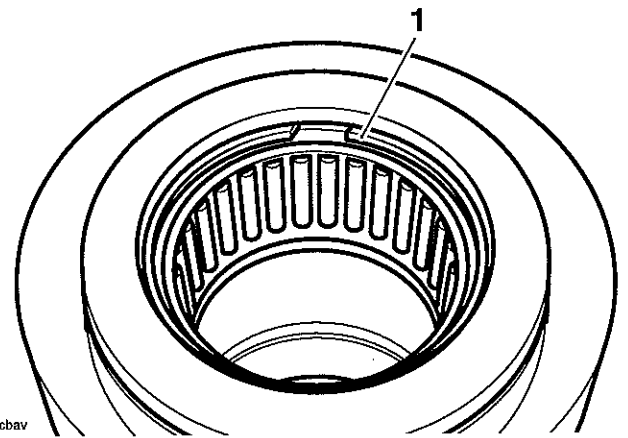

cbav

1. Bearing Retaining Ring

8. Open the vice to a distance that will accept the hub, new left hand bearing and service tool 3880075-T0301 all aligned together inside the soft vice jaws. Align the Small end of tool 3880075-T0301 to the new bearing.

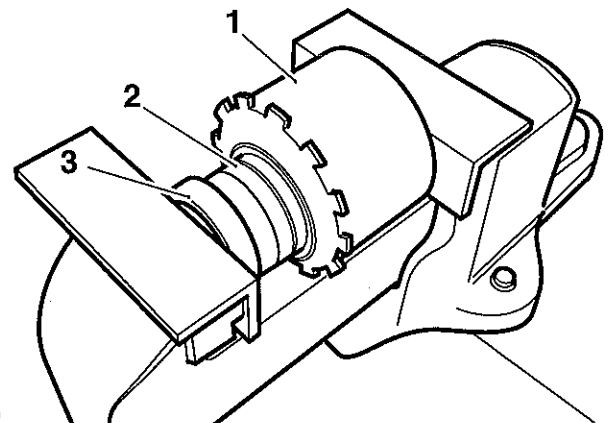

cdga

1. Hub
2. Left hand bearing
3. Service Tool 3880075-T0301

- Progressively close the vice until outer race of the left hand new bearing is pushed fully up to the inner flange inside the hub. Open the vice and collect the hub and tool then place the tool aside.



Caution

Ensure the hub, new bearing and tool remain in alignment throughout the assembly process. Misalignment of any of these items could cause damage to the bearing and/or the hub.

Should misalignment occur at any point, remove the components, check and rectify any damage and then repeat the bearing installation process.

- Retain the new bearing by fitting a new retaining ring to the groove inside the hub. Ensure the ring is retained in the groove through its entire circumference.

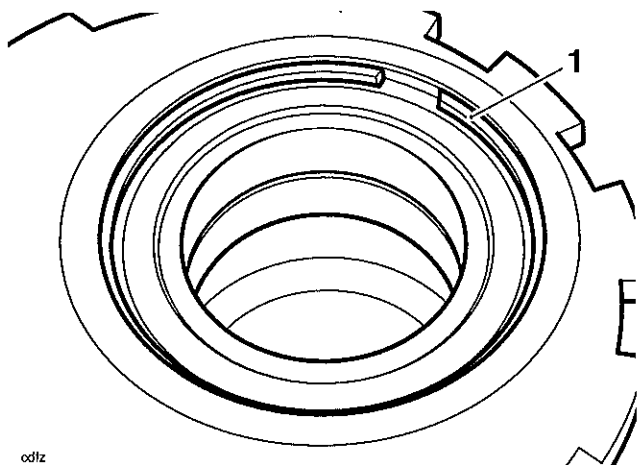

1. Bearing Retaining Ring

- Lubricate a new outer seal's knife-edge with grease to NLGI 2 specification (we recommend Mobil grease HP222). Position the outer hub seal to the hub and push it evenly and fully into place against the bearing retaining ring.

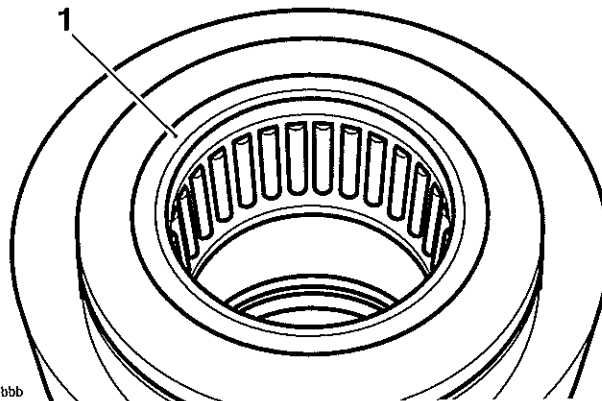

1. Outer Hub Seal

- Lubricate the new bearing with 5 grammes of grease to NLGI 2 specification (we recommend Mobil grease HP222).
- Thoroughly clean the hub-bore in the swinging arm.
- Refit the hub (see page 12-19).

16 Frame and Bodywork

Table of Contents

| | |
|---|-------|
| Exploded View - Frame..... | 16.2 |
| Exploded View - Seat Rails..... | 16.3 |
| Exploded View - Cockpit and Mountings..... | 16.4 |
| Exploded View - Lower Fairings..... | 16.5 |
| Exploded View - Rear Panels..... | 16.6 |
| Exploded View - Footrests and Mountings..... | 16.7 |
| Seat..... | 16.8 |
| Removal..... | 16.8 |
| Refit..... | 16.8 |
| Frame, Footrests and Fixings..... | 16.8 |
| Inspection..... | 16.8 |
| Rear Panel..... | 16.9 |
| Removal..... | 16.9 |
| Installation..... | 16.9 |
| Left and Right Facia / Cockpit Infill Panels..... | 16.9 |
| Removal..... | 16.9 |
| Installation..... | 16.10 |
| Fuse Box / Stowage Box..... | 16.10 |
| Removal..... | 16.10 |
| Installation..... | 16.11 |
| Lower Fairing..... | 16.11 |
| Removal..... | 16.11 |
| Installation..... | 16.12 |
| Windscreen and Under-Screen Trim..... | 16.12 |
| Removal..... | 16.12 |
| Installation..... | 16.12 |
| Cockpit..... | 16.13 |
| Removal..... | 16.13 |
| Installation..... | 16.13 |

Frame and Bodywork

Exploded View - Frame

All engine mouning fixings - see text in section 9

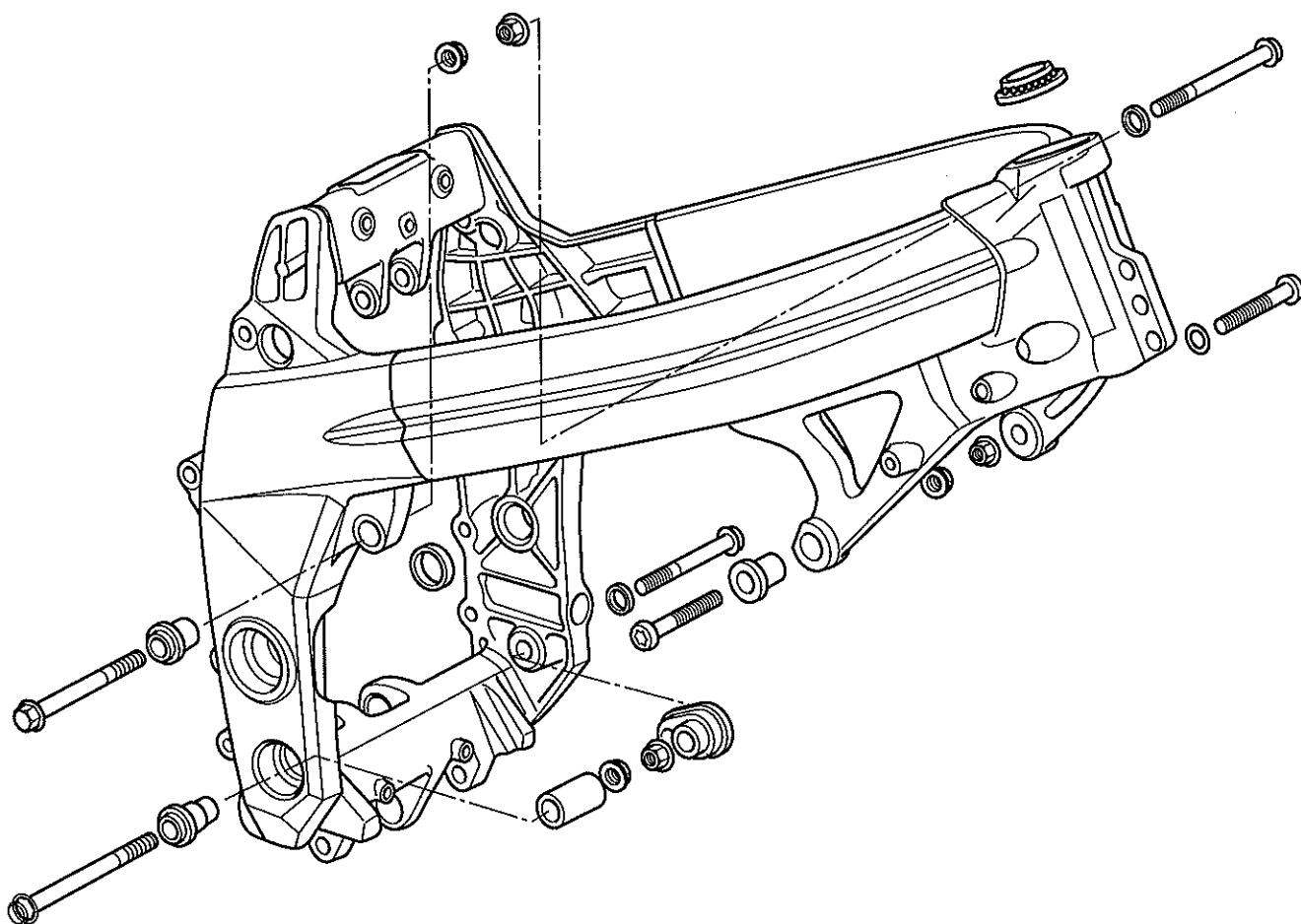

Exploded View - Seat Rails

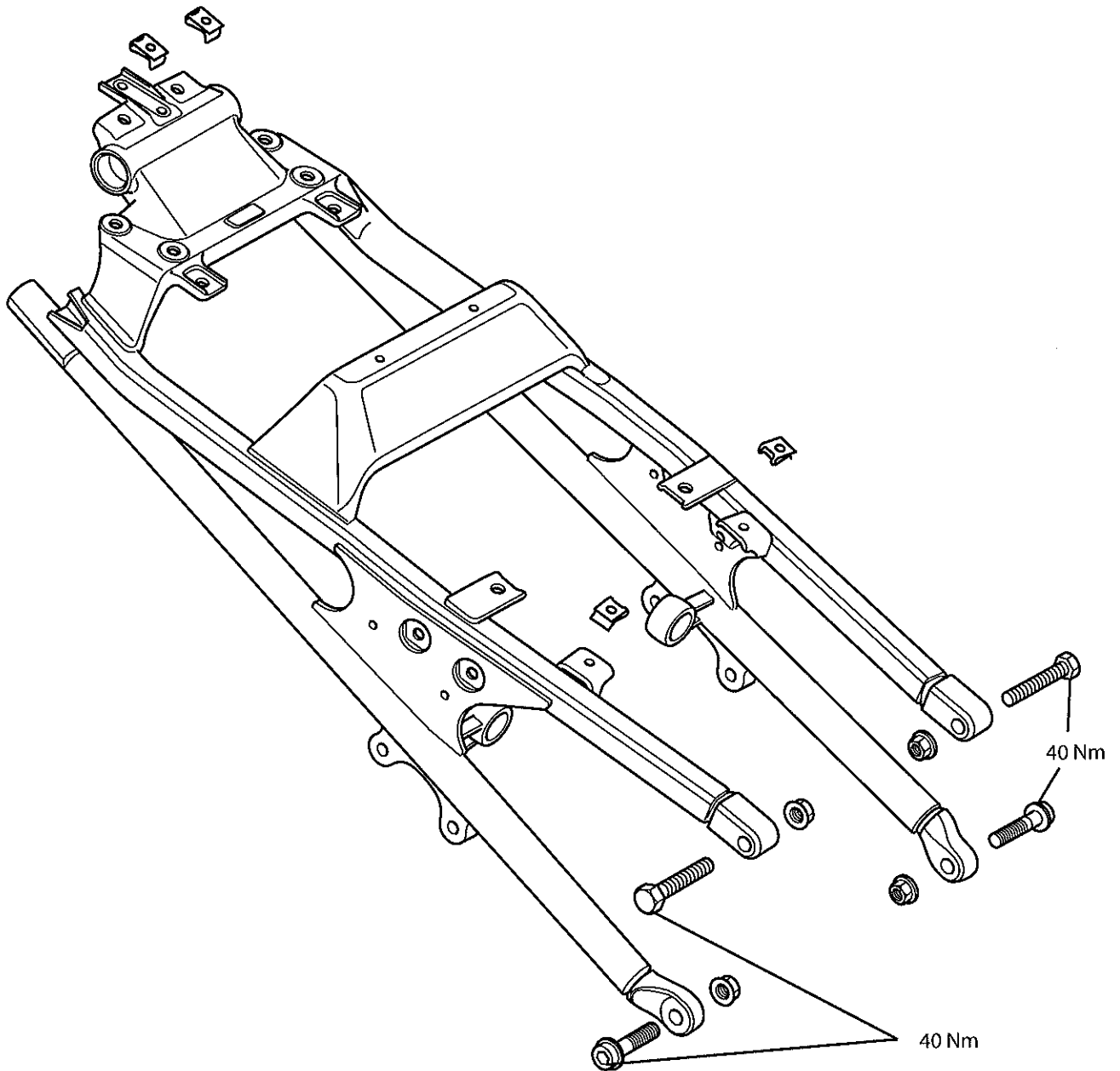

Frame and Bodywork

Exploded View - Cockpit and Mountings

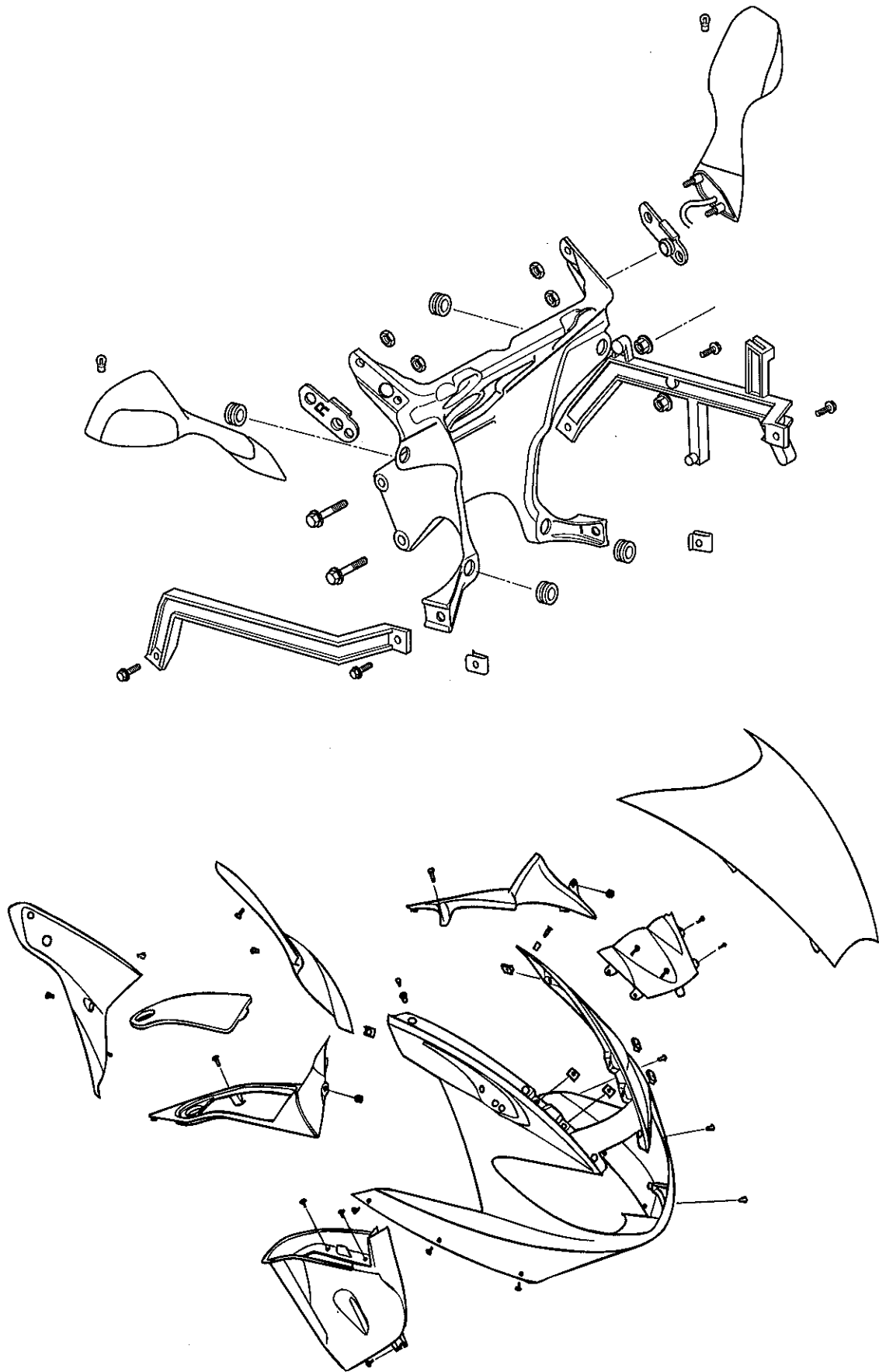

All fixings - see text

Exploded View - Lower Fairings

All fixings - see text

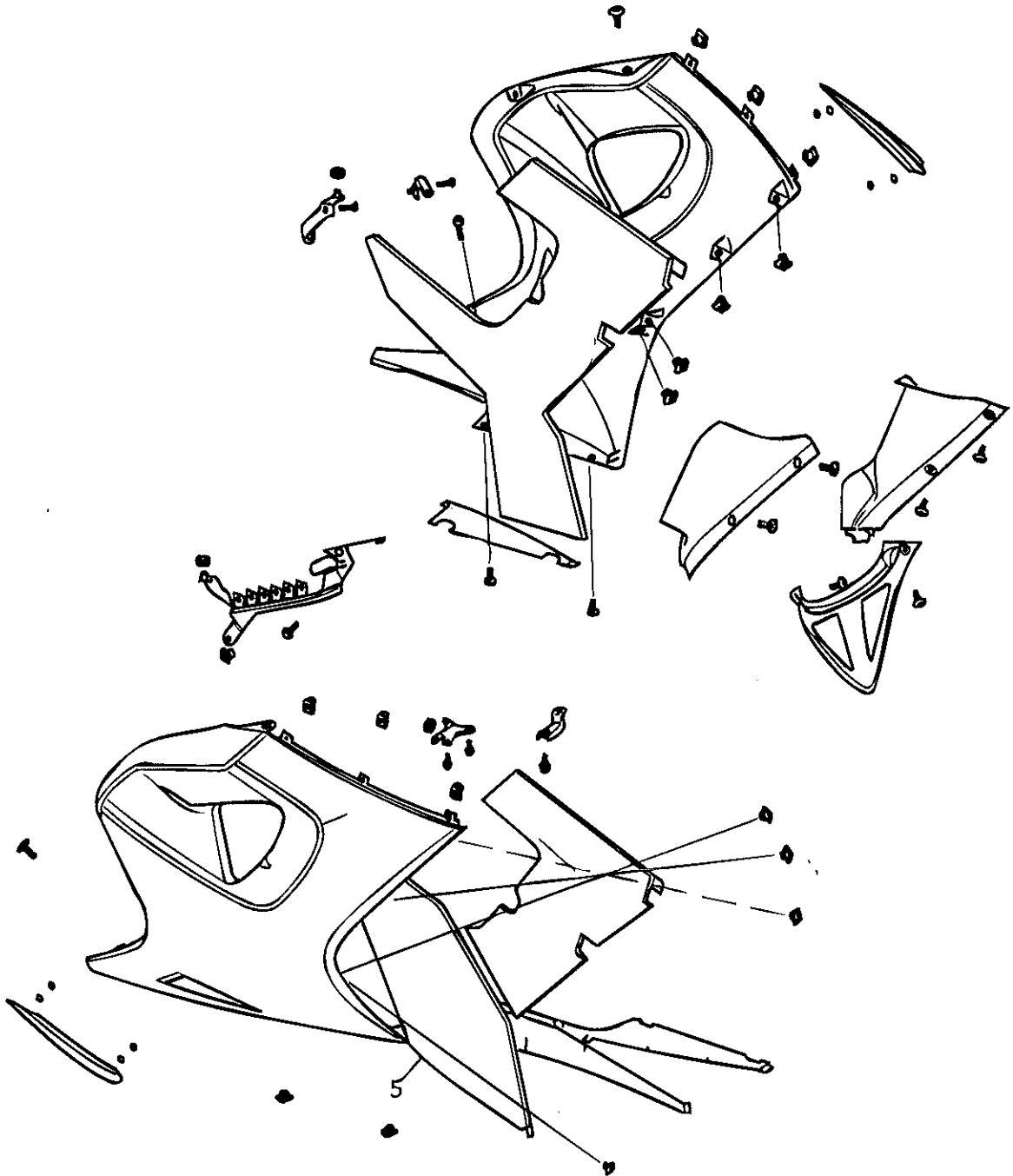

Frame and Bodywork

Exploded View - Rear Panels

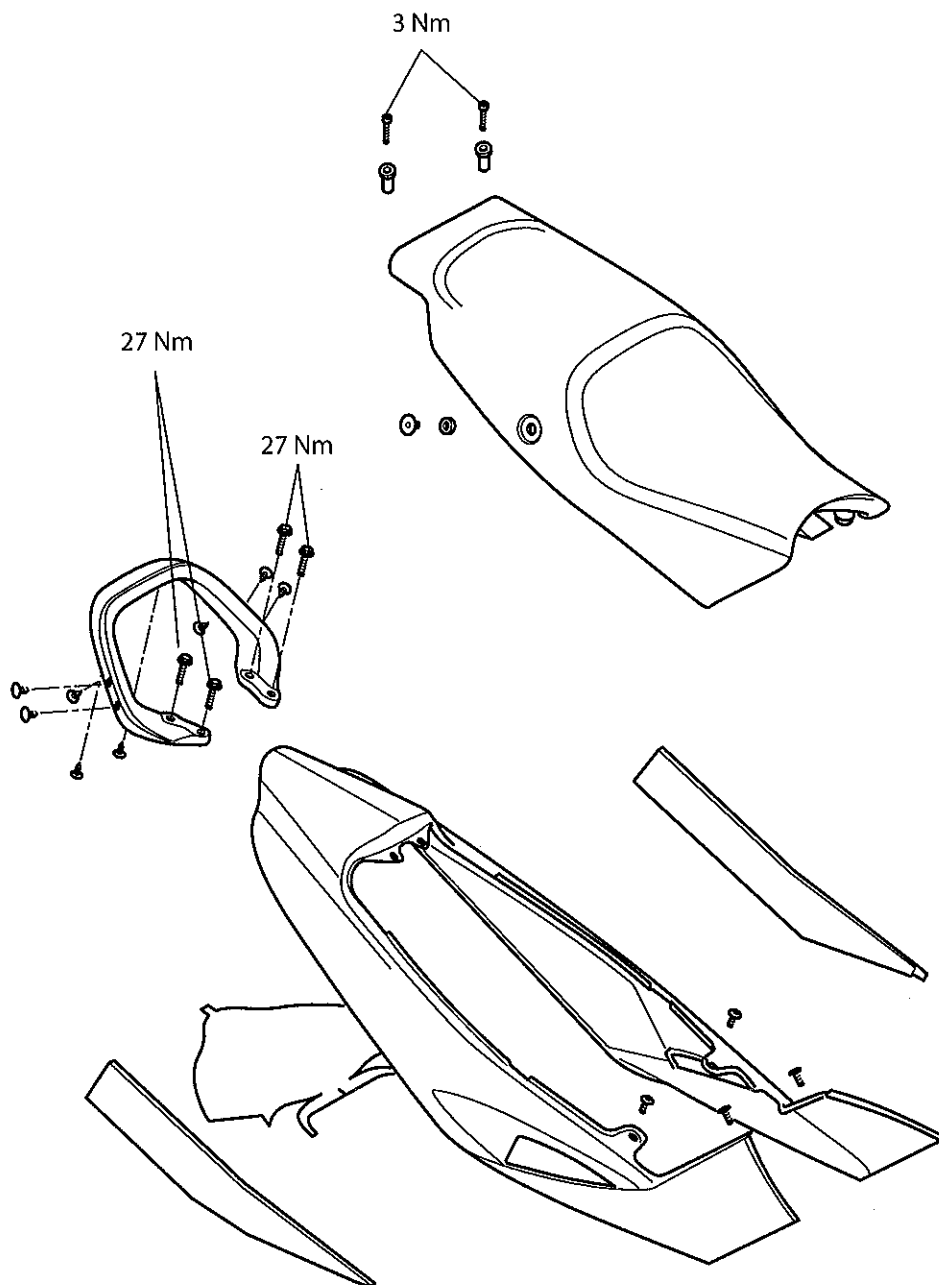

All body panel fixings - 3 Nm

Exploded View - Footrests and Mountings

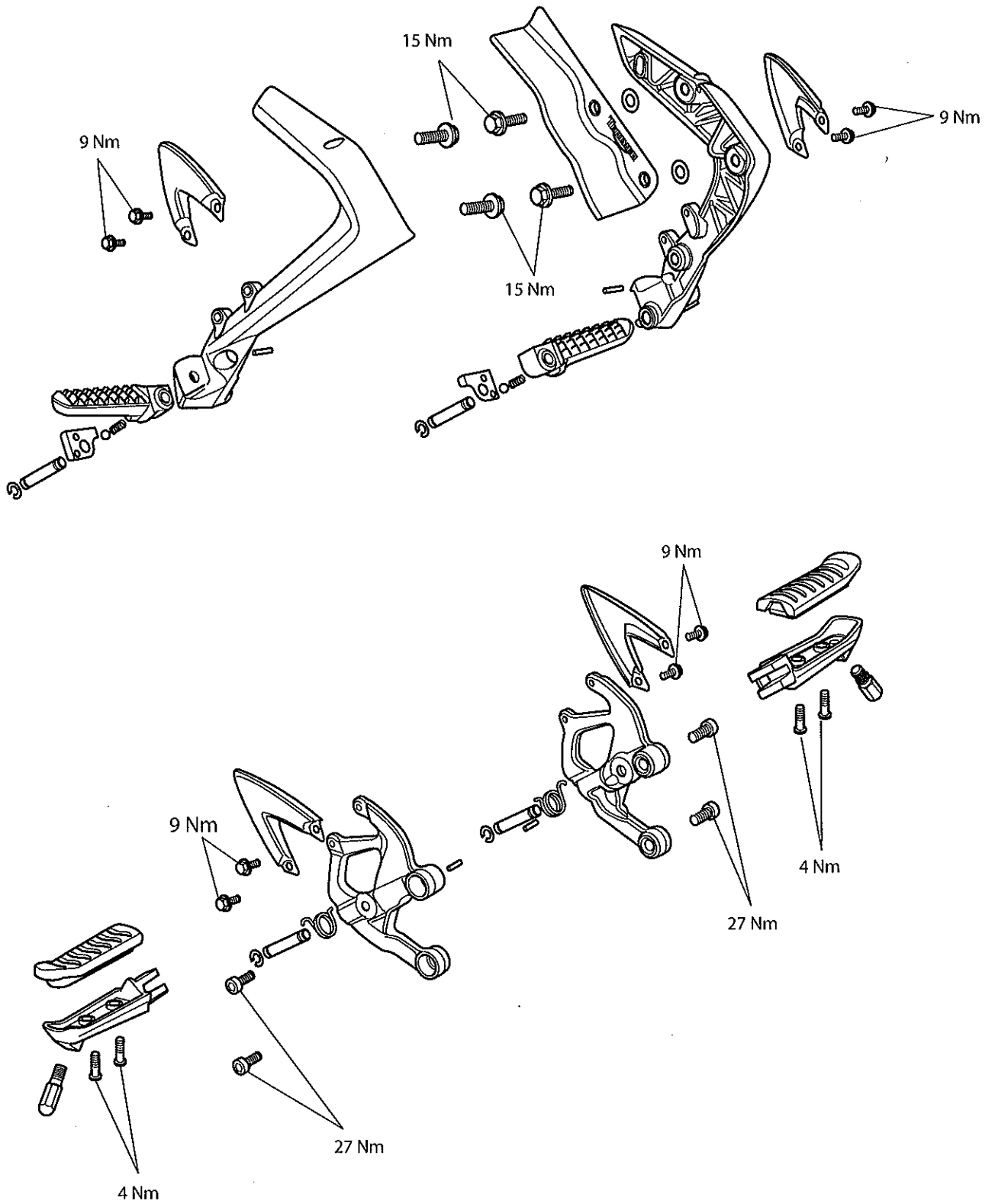

Frame and Bodywork

Seat

Removal

The seat fasteners are located under the rear edge of the seat.

1. Push back the rear edge of the seat and unscrew the exposed fixings. Collect the spacers from beneath the fixings.

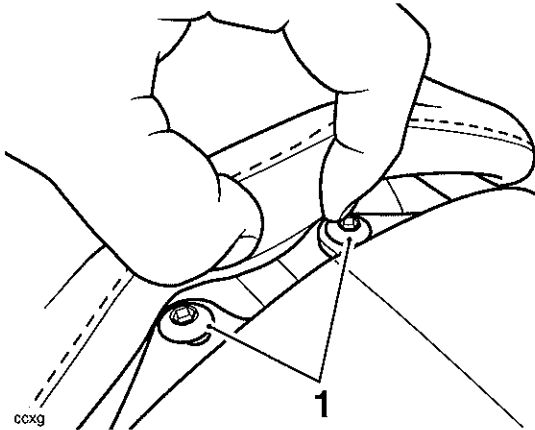

1. Seat fasteners

2. To detach the seat, lift the rear of the seat and slide it rearwards.

Refit

1. Position the seat to the fuel tank bridge and engage the front lip.
2. Press down on the rear of the seat to engage.
3. Push back the rear edge of the seat and secure the fixings. Tighten to **3 Nm**.
4. Grasp the seat and ensure that it is securely retained.

Frame, Footrests and Fixings

Inspection

1. Inspect the frame, footrests and fairings for damage, cracks, chafing and other dangerous conditions. Check fairing and frame fixings for security.
2. Inspect the bank angle indicators on the rider's footrests for wear. The bank angle indicators are worn out when 5mm of the bank indicator remains.

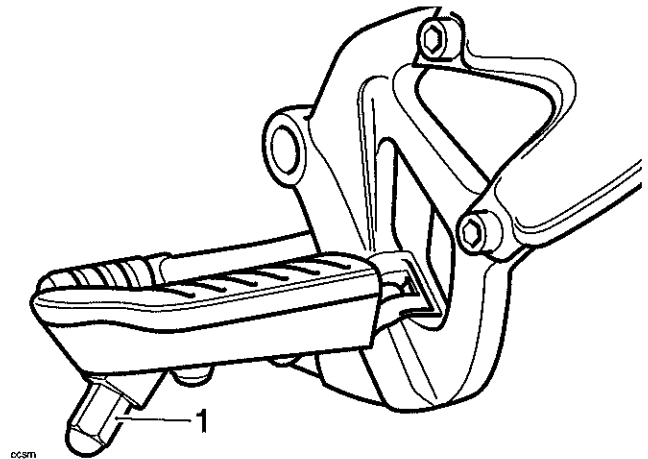

1. Bank angle indicator

Warning

Use of a motorcycle with bank angle indicators worn beyond the maximum limit will allow the motorcycle to be banked to an unsafe angle. Banking to an unsafe angle may cause instability, loss of control and an accident causing injury or death.

Warning

If the motorcycle is involved in an accident or collision it must be taken to an authorised Triumph dealer for repair or inspection. Any accident can cause damage to the motorcycle which, if not correctly repaired, may cause another accident which may result in injury or death.

Warning

The frame must not be modified as any modification to the frame such as welding or drilling may weaken the frame resulting in an accident.

Rear Panel

Removal

1. Remove the seat (see page 16-8).
2. Disconnect the battery, negative (black) lead first.
3. Remove the grab rail.
4. To release the rear panel assembly, remove the fixings shown in the illustration below and collect the four washers on the two rearmost fixings.

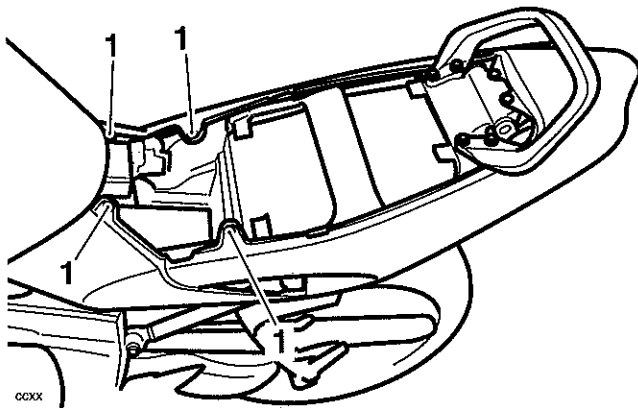

1. Rear Panel Fixings

5. Gently pull the panel outwards.
6. Withdraw the panel assembly from the rear of the motorcycle.

Installation

1. Installation is the reverse of removal noting the following.

Note:

- The two rearmost fixings have a washer above and below the panel mountings.
- Tighten fixings to 3 Nm.
- Reconnect the battery, positive (red) lead first.

Left and Right Facia / Cockpit Infill Panels

Removal

Note:

- Follow the same procedure for both left and right hand sides.

1. Remove the seat (see page 16-8).
2. Disconnect the battery, negative (black) lead first.

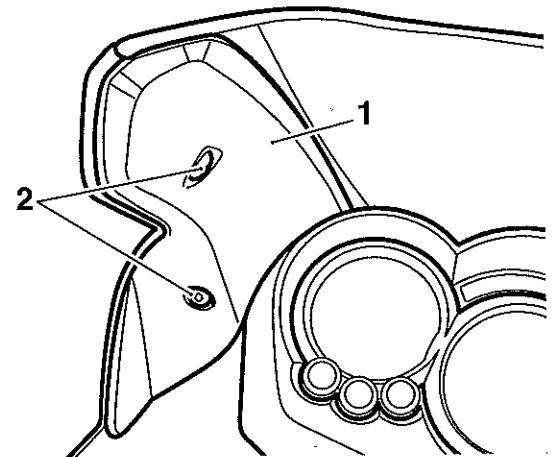

1. Facia infill panel

2. Fixings

3. Remove the two screws securing the upper facia infill panel. Note the length and position of the screws.
4. To remove the facia infill panel ease the top towards the motorcycle centre line. This will allow the lip under the instruments to be withdrawn. Pull to the rear to extract the bayonet from the grommet in the cockpit infill panel.
5. Remove the lid from the stowage compartment.

Frame and Bodywork

6. Remove the screws securing the cockpit infill panel.

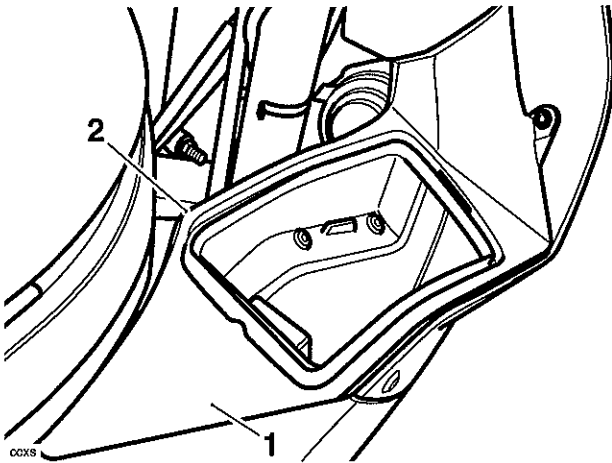

1. Cockpit infill panel
2. Fixings

7. The rear of the cockpit infill is located into the fairing with a hook. The panel must be moved forwards until the hook is clear of the slot.
8. Remove the panel.

Installation

1. Installation is the reverse of removal noting the following.

Note:

- Tighten fixings to 5 Nm.
- Reconnect the battery, positive (red) lead first.

Fuse Box / Stowage Box

Removal

1. Remove the right hand facia and cockpit infill panels (see page 16-9).
2. Remove the right hand lower fairing (see page 16-11).
3. Remove the contents of the stowage compartment.

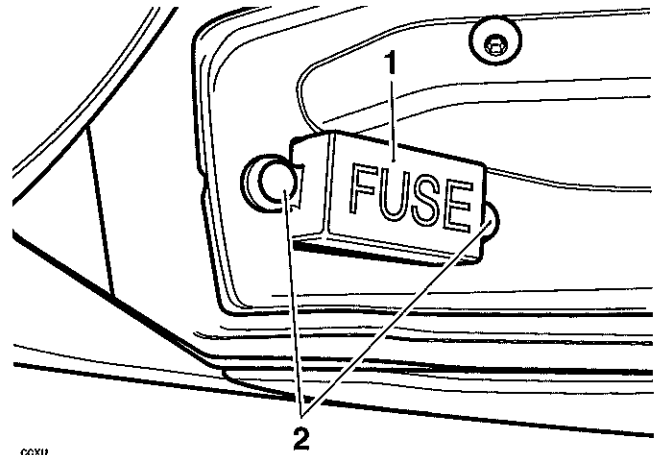

1. Fuse box
2. Fuse box fixings

4. Remove the fir tree fixings securing the fuse box to the stowage compartment. Detach the fuse box.
5. Remove the three screws securing the stowage box to the subframe.
6. Remove the stowage box.

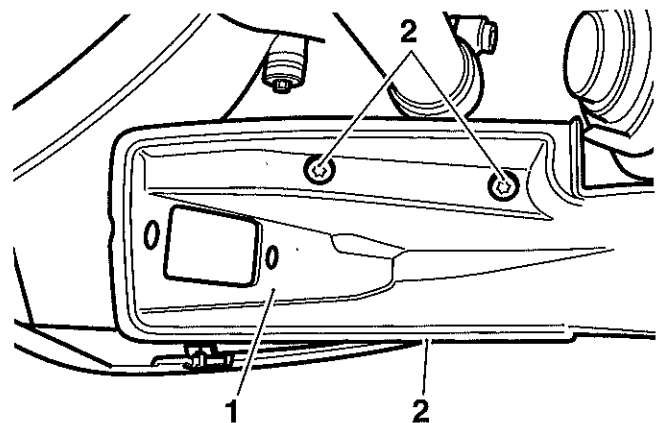

1. Stowage box
2. Stowage box fixing locations

Installation

1. Installation is the reverse of removal noting the following.

Note:

- Tighten the stowage box fixings to 6 Nm.
- Tighten the lower fairing fixings to 5 Nm.
- Reconnect the battery, positive (red) lead first.

Lower Fairing

Removal

Note:

- The cockpit does NOT need to be removed in order to remove the lower fairings.

1. Remove the seat (see page 16-8).
2. Disconnect the battery, negative (black) lead first.
3. Remove the facia and cockpit infill panels (see page 16-9).
4. Remove the two screws securing the fairing lower halves to each other.

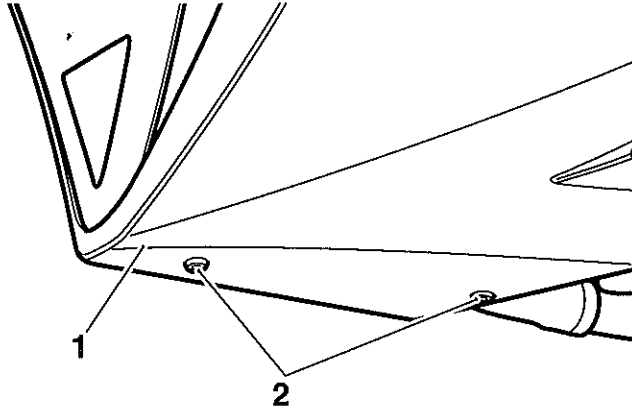

cchd

1. Lower Fairing
2. Fixings

5. Remove the two screws holding the oil cooler infill panel. Withdraw the panel in an upward direction.

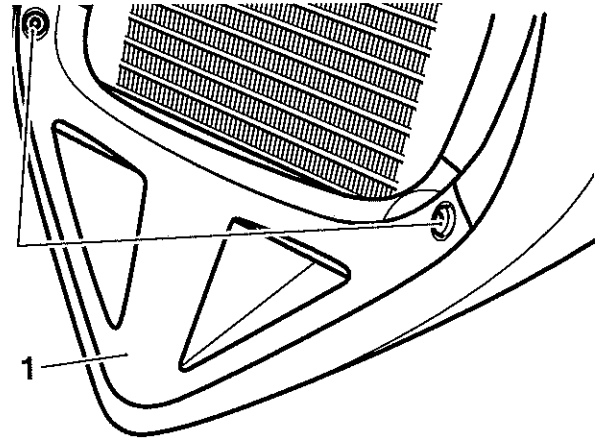

1. Oil cooler infill panel
2. Fixings

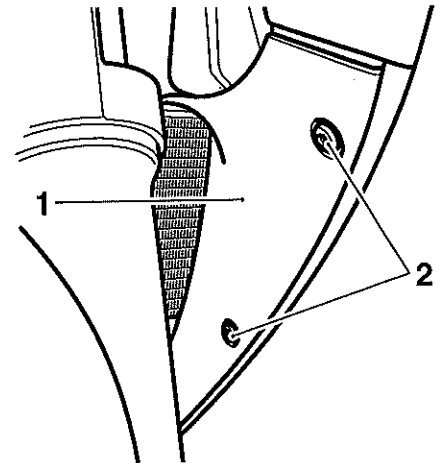

ccxv

1. Radiator infill panel (LH shown)
2. Fixings

6. Remove the two screws securing each of the radiator infill panels.
7. Remove the two screws securing each fairing to the fairing brackets.

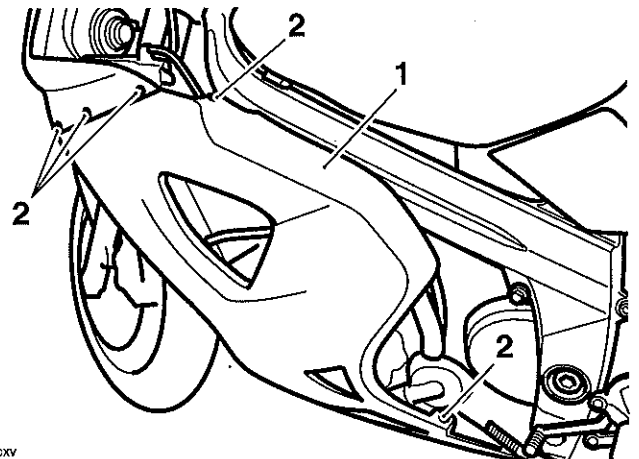

ccxv

1. Lower Fairing (RH shown)

Frame and Bodywork

2. Fairing Retaining Screws

8. Remove the three screws securing each fairing to the cockpit.
9. Ease the panel away from the cockpit to remove it.

Installation

1. Position each fairing to the rear of the upper mounting.
2. Refit the fairing to the cockpit, tighten the fixings to **5 Nm**.
3. Refit the fairings to the fairing brackets, tighten the fixings to **5 Nm**.
4. Refit the radiator infill panels, tighten the fixings to **6 Nm**.
5. Refit the oil cooler infill panel, tighten the fixings to **6 Nm**.
6. Refit the lower fairing fixings, tighten the fixings to **5 Nm**.
7. Refit the facia and cockpit infill panels (see page 16-11).
8. Reconnect the battery, positive (red) lead first.
9. Refit the seat (see page 16-8).

Windscreen and Under-Screen Trim

Removal

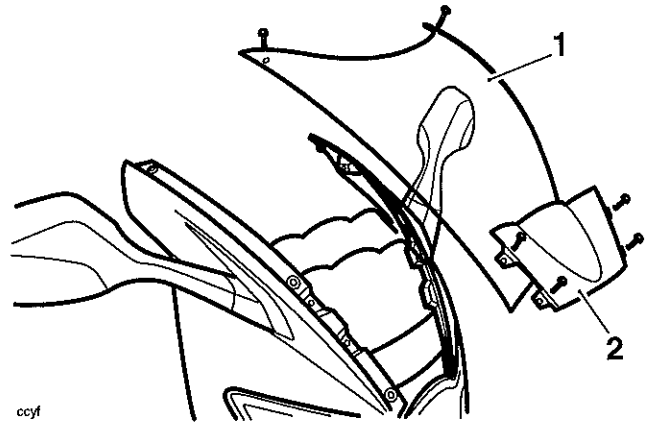

1. Windscreen
2. Under-screen trim

1. Release the windscreen upper fixings.
2. Slide the windscreen upwards and to the rear.
3. Release the fixings securing the under-screen trim and remove the trim.

Installation

Installation is the reverse of removal noting the following.

Note:

- Tighten fixings to **5 Nm**.

Cockpit

Removal

Note:

- The cockpit is removed as an assembly. It is not necessary to remove the lower fairings, instruments or headlight unit.

- Remove the seat (see page 16-8)
- Disconnect the battery, negative (black) lead first.
- Remove the facia and cockpit infill panels (see page 16-9).
- Remove the windscreen and under-screen trim (see page 16-12).

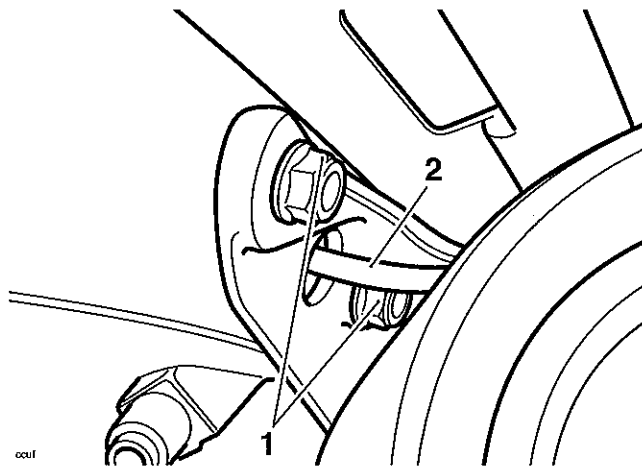

- Mirror fixings
- Indicator wires

- Release the two nuts on each mirror.
- Disconnect the direction indicators at their multiplugs in the area under the screen trim.

- Remove both mirrors.

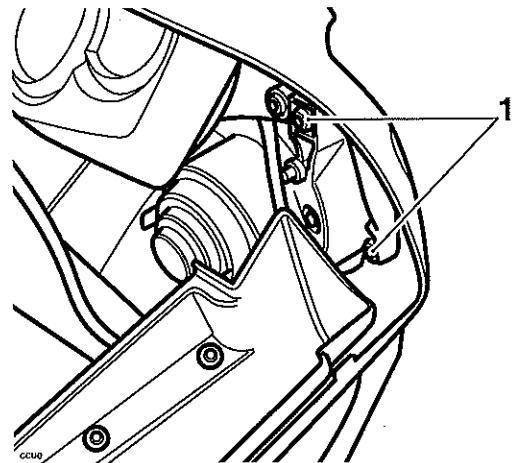

- Cockpit to headlight screws (right hand shown)
- Remove the four screws securing the cockpit to the headlight assembly

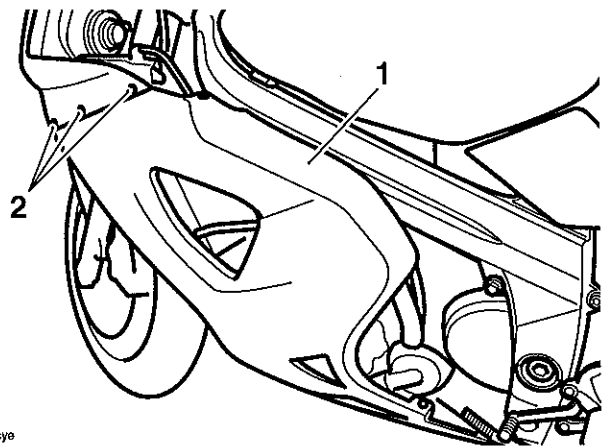

- Lower fairing
- Cockpit to lower fairing screws

- Remove the three screws securing the cockpit to each lower fairing.
- Remove the cockpit in a forward direction.

Installation

- Position the cockpit to each lower fairing.
- Refit the cockpit to the fairings, tighten the fixings to **5 Nm**.
- Refit the fairing to the headlight assembly, tighten the fixings to **6 Nm**.
- Fit the mirrors, tighten the fixings to **9 Nm**.
- Refit the instruments (see page 17-17).
- Refit the windscreen and under-screen trim (see page 16-12).

Frame and Bodywork

7. Refit the facia and cockpit infill panels (see page 16-11).
8. Connect the battery, positive (red) lead first.
9. Refit the seat (see page 16-8).